

13AT696H190 LT-165 (1997)  
46" Mowing Deck

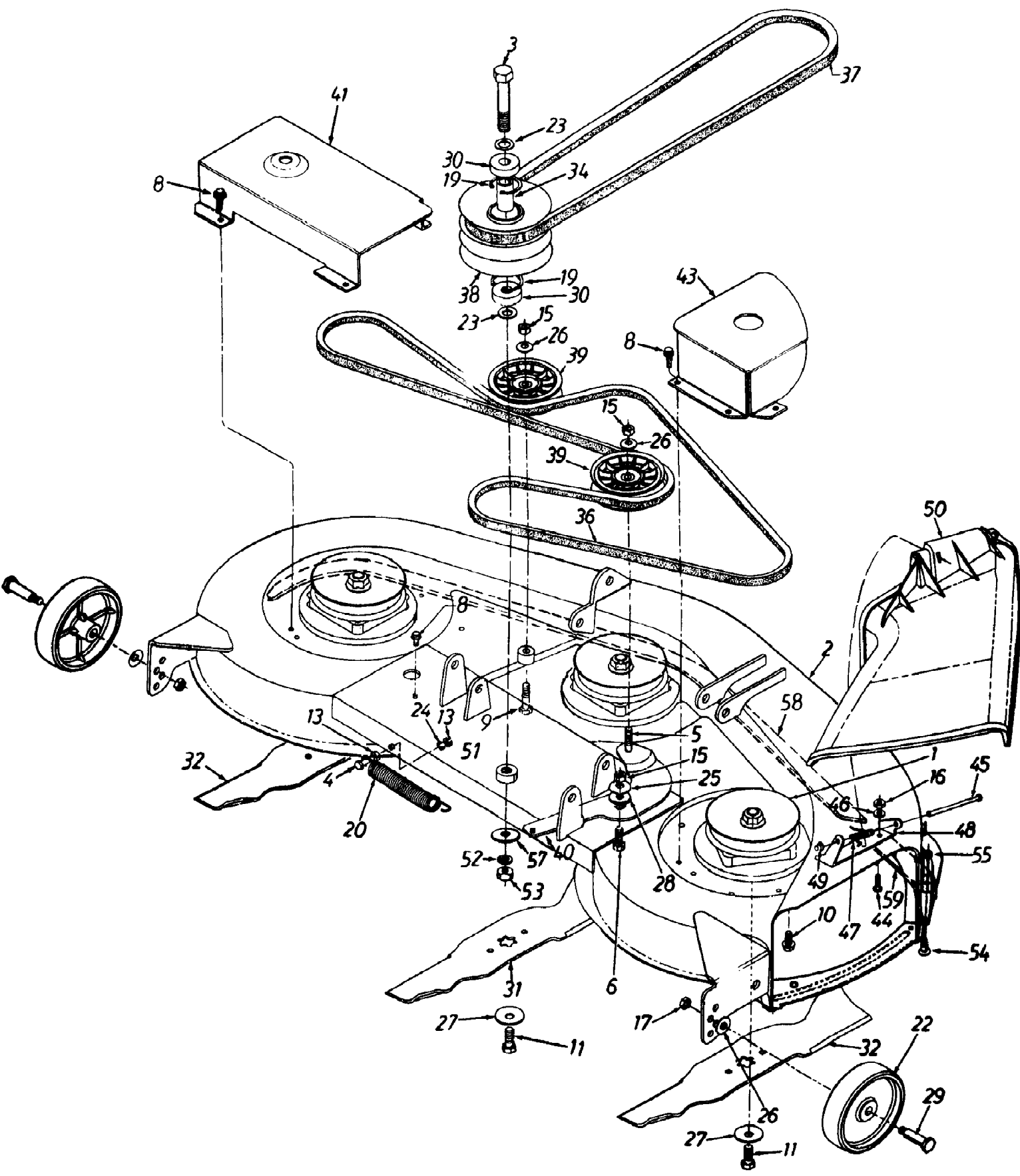

13AT696H190 LT-165 (1997)  
46" Mowing Deck

Page 2 of 22

Ref #	Part Number	Qty	S/P/F	Description
1	618-0240	1	S	Blade Spindle Ass'y.
2	783-0114A	1		46" Deck Ass'y.
	683-0067	1		46" Deck Ass'y. Comp. (For Service)
3	710-0298	1		Hex Bolt 5/8-18 x 3.5" Lg.
4	710-0428	1		Hex Bolt 1/4-28 x 1.25" Lg.
5	710-0459	1	S	Hex Bolt 3/8-24 x 1.5" Lg.
6	710-0152	1	S	Hex Bolt 3/8-24 x 1" Lg.
8	710-0599	1	/P	Hex Wash. Hd, TT-Tap Scr. 1/4-20 x .5" Lg.
9	710-0151	1	/P	Hex Bolt 3/8-24 x 2" Lg.
10	710-1260	1	S	Hex Flange Bolt 5/16-24 x .75" Lg.
11	710-1262	1	/P	Hex Patch L-Bolt 7/16-20 x 1" Lg,
13	712-0138	1	S	Hex Nut 1/4-28 Thd.
15	712-0241	1	/P	Hex Nut 3/8-24 Thd.
16	712-0287	1	S	Hex Nut 1/4-20 Thd.
17	712-0181	1	S	Hex Top Jam Nut 3/8-16 Thd.
19	716-3020	1	S	Int. Snap Ring
20	732-0594A	1	S	Ext. Spring .88" O.D. x 6.17"
22	734-0973	1	/P	Deck Wheel
23	736-0290	1	/P	FI-Wash. .635" I.D. x 1" O.D. x .06"
24	736-0329	1	S/F	L-Wash. 1/4" I.D.
25	736-0331	1	/P	Bell-Wash. 3/8" x 1.125" x .062"
26	736-0105	1	/P	Bell-Wash. 3/8" x .87" x .064"
27	736-0510	1	S	Bell-Washer
28	738-0347	1	S	Shoulder Spacer.625" I.D. x .169"
29	738-0373	1	S	Shld. Bolt .498" x 1.525"
30	741-0524	1	S	Ball Brg. .625" I.D. x 1.574" O.D. x .47"
31	742-0645	1	S	High Lift Blade 14.88" Lg.
32	742-0644	1	S	High Lift Blade 16.28" Lg.
34	750-0932A	1	S	Spacer .635" I.O. x .088" O.D.
36	754-0440	1	S	V-Belt
37	754-0439	1	S	V-Belt
38	756-0638	1		Pulley Double Deck 5" O.D.
39	756-0627	1	S	Flat Idler Pulley 3.5 O.D.
40	783-0046	1	S	Idler Deck Bracket
41	783-0063A	1	/P	Belt Cover L.H.
43	17258A	1	S	Belt Cover Brkt. R.H.
44	710-0258	1	S	Hex Bolt 1/4-20 x .62" Lg.
45	711-0792	1	S	Hinge Pin
46	736-0270	1	/P	Bell-Wash. 1/4" I.D.
47	732-0602	1	S	Torsion Spring
48	703-1693	1	S	Hinge Mtg. Brkt.
49	726-0106	1	S	Push Nut
50	731-1032	1	S	Chute Ass'y. Comp. (Incl. Ref. 45, 47, 48, 49, 50)
51	750-0960	1	S	Spacer .635" I.D. x 1" O.D.
52	736-0158	1	S	L-Wash. 5/8" I.D.
53	712-0337	1		Hex Nut 5/8-18 Thd.
54	710-0167	1	/P	Carriage Bolt 1/4-20 x .5" Lg.
55	712-0271	1	/P	Hex Sems Nut 1/4-20 Thd.
57	736-3088	1		FI-Wash. .635" I.D.
58	783-0141	1		Center Deck Skirt
59	783-0142	1	S	R.H. Deck Skirt

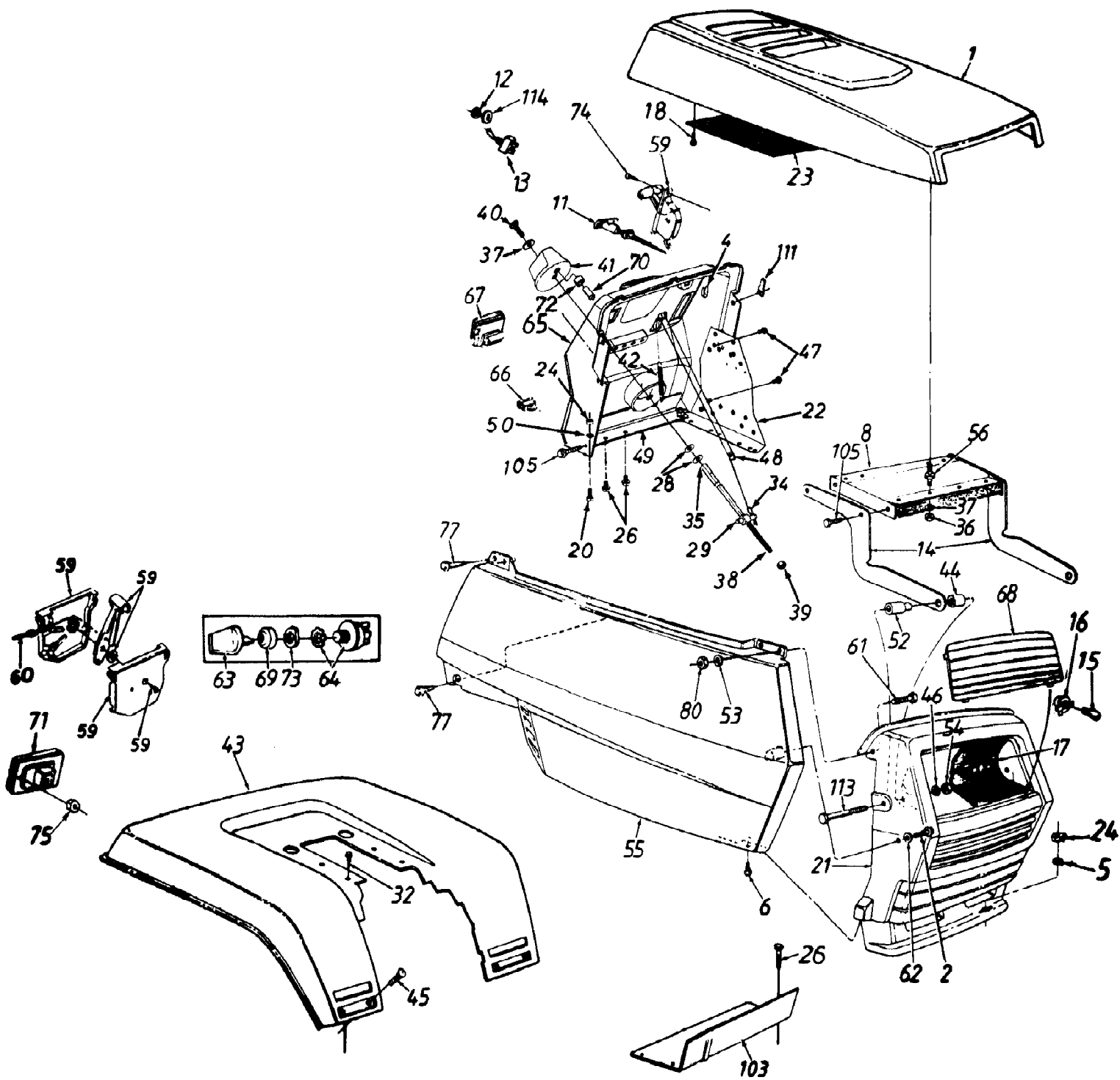

13AT696H190 LT-165 (1997)  
Hood, Grille And Rear Fender

Page 4 of 22

Ref #	Part Number	Qty	S/P/F	Description
1	731-1429	1	S	Hood
2	710-0896	1	/P	Hex Wash. B-Tap Scr. 1/4 x .62" Lg.
?3	726-0233	1	/P	Bolt Retainer 1/4" I.D.
4	17782	1		Retainer Clip
5		1		UNKNOWN
6	710-0351	1	/P	Truss Mach. B-Tap Scr. #10 x .5" Lg.
?7	726-0211	1	S	U-Nut 5/16-18 Thd.
8	16903A	1	S	Hood Plate
11	746-3021	1		Choke Control
12	712-3014	1		Hex Nut 1/2-27 Thd.
13	725-0893	1	S	Toggle Switch
14	16902A	1		Hood Hinge
15	725-0963	1	S	Lamp
16	725-1649	1	S	Twist Lock - Lamp Socket
17	777-8516	1		Reflector - Headlight
18	710-0227	1	/P	Hex Wash. Hd. AB-Tap Scr. #8 x .5" Lg.
20	710-0118	1	S/F	Hex Bolt 5/16-18 x .75" Lg.
21	731-1430B	1	S	Grille Code: N Notates a new part (not previously existing)
22	17300D	1		Dash Support Bracket
23	723-0416	1		Screen
24	712-0265	1	/P	Hex Sems Nut 5/16-18 Thd.
?25	736-0176	1	S	FI-Wash. 1/4" I.D. x .93" O.D.
26	710-0603	1	/P	Hex Wash. Hd. 6-Tap Scr. 5/16-18 x .5" Lg.
?27	710-0429	1	S	Hex B-Tap Scr. #10 x .38" Lg.
28	736-0267	1	S	FI-Wash. 3/8" I.D. x .875" O.D.
29	711-1002	1		Adj. Ferrule 3/8-8 Thd.
32		1		UNKNOWN
?33	736-0242	1	/P	Bell-Wash. .345" i.D. x .88"
34	714-0101	1	S	Hairpin Clip
35	716-0125	1	S	"E"-Ring .375" Dia.
36	712-3006	1	/P	Hex Nut 1/4-20 Thd. (Gr. 5)
37	736-0270	1	/P	Bell-Wash. .265" I.D. x .75"
38	747-0898	1		Adjustment Rod
39	712-0449	1		Hex Nut 3/8-8 Twin Thd.
40	710-3015	1	/P	Hex Bolt 1/4-20 x .75" Lg.
41	720-0236	1	S	Plastic Knob
42	732-0732	1		Ext. Spring 3.21" Lg.
43	783-0329	1	S	Rear Fender Code: N Notates a new part (not previously existing)
44	750-0755	1		Spacer .33" I.D. x .625" O.D.
45	710-0167	1	/P/F	Carriage Bolt 1/4-20 x .50" Lg.
46	736-0278	1		FI-Wash. .328" I.D. x .68" O.D.
47	710-0599	1	/P	Hex Wash. Hd. Scr. 1/4-20 x .5" Lg.
48	727-0460	1	S	Indicator Strip
49	783-0120	1	S	Indicator Bracket
50		1		UNKNOWN
52	750-0754	1		Shld. Spacer .33" I.D.
53	736-0142	1	S	FI-Wash. .281" I.D. x .5" O.D.
54	712-0158	1	S	Hex Cent. L-Nut 5/16-18 Thd.
55	731-1432A	1	S	Side Cover - R.H.
	731-1431A	1		Side Cover - L.H.

13AT696H190 LT-165 (1997)  
Hood, Grille And Rear Fender

Page 5 of 22

Ref #	Part Number	Qty	S/P/F	Description
56	710-1034	1		Double Ended Stud 1/4-20 Thd.
59	831-0823A	1	/P	Throttle Control Box Ass'y.
60	746-0634	1	S	Throttle Control Wire 22" Lg.
61	710-0258	1	S/F	Hex Bolt 1 4-20 x .62" Lg.
62	736-0173	1	/P	Fl-Wash. .281" I.D. x .73" O.D.
63	725-1341B	1	/P	Ignition Key
64	725-1396	1	S	Ignition Switch
65	731-1510	1	S	Dash Panel
66	725-0634	1	S	Light Switch
67	725-0925	1	S	Ammeter
68	731-1038A	1	S	Lens
69	725-1347	1	/P	Ignition Switch Cap
70	732-0675	1		Ball Plunger
71	725-3018	1		Taillight
72	750-0526	1		Spacer
73	725-1346	1	S	Ignition Switch Nut
74	710-0779A	1	/P	Truss Mach. AB-Tap Scr. #10 x .5" Lg.
75	710-0936	1		Truss Hd. AB-Tap Scr. #6 x .62" Lg.
77	710-0642	1	/P	Hex Wash. Hd. Tap Scr. 1/4 x .75" Lg.
80	712-0291	1	S	Hex L-Nut 1/4-20 Thd.
?94	712-0147	1	/P	Speed Nut #10-24 Thd.
103	17633A	1	S	Gasoline Tank Support
105	710-0599	1	/P	Hex Tap Scr. 1/4-20 x .5" Lg.
111	712-0185	1		Speed Nut 1/4-20 Thd.
113	710-0176	1	/P	Hex Bolt 5/16-18 x 2.75"
	629-0309	1	S	Headlight Harness (Not shown)
114		1		UNKNOWN

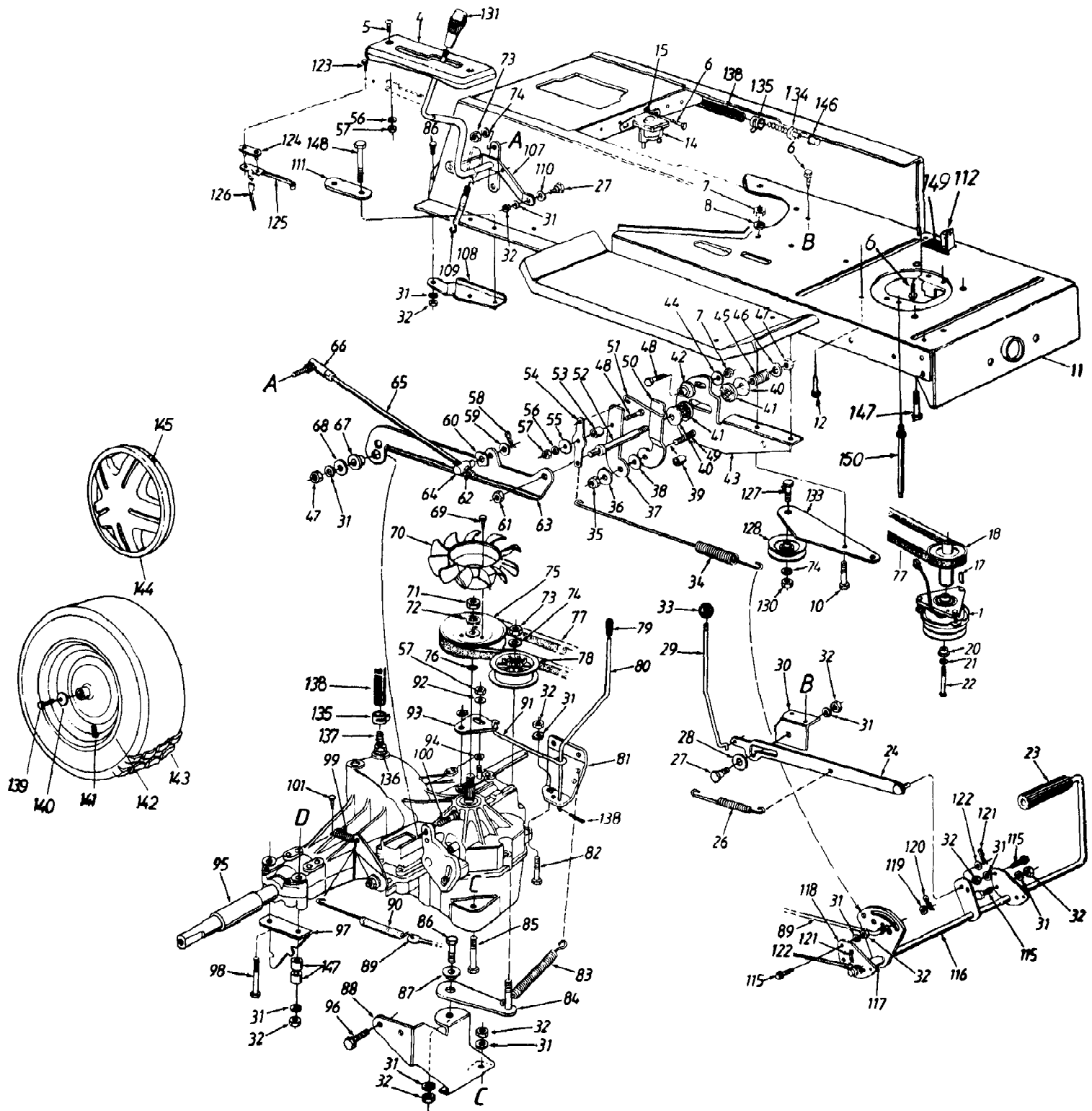

13AT696H190 LT-165 (1997)  
Lower Frame, Clutch And Controls

Page 7 of 22

Ref #	Part Number	Qty	S/P/F	Description
1	717-1459	1	S	Electric Clutch
4	731-1647	1		Index Bracket
5	710-0924	1	/P	Pan Hd. Mach. Scr. 1/4-20 x .75" Lg.
6	710-0599	1	/P	Hex Wash. Hd. TT-Tap Scr. 1/4-20 x .5" Lg.
7	712-0138	1	S	Hex Nut 1/4-28 Thd.
8	736-0329	1	S/F	L-Wash. 1/4" I.D.
?9	750-0777	1		Shld. Spacer .38" I.D.
10	710-0412	1	/P	Hex Bolt 1/4-28 x .75" Lg.
11	783-0310B	1	S	Lower Frame Ass'y.
12	710-1315	1	/P	Hex Tap Scr. 3/8-16 x 1.25" Lg.
14	725-1426	1	S	Solenoid
15	736-0222	1	S	Ext. L-Wash. 1/4" I.D.
17	714-0118	1	/P	Sq. Key 1/4" x 1.5" Lg.
18	756-0978	1	S	Engine Pulley
?19	17418	1	S	Torque Brkt.
20	738-0785	1	S	Shld. Spacer .445" I.D.
21	736-0171	1	S/F	L-Wash. 7/16" I.D.
22	710-0561	1		Hex Bolt 7/16-20 x 2.5" Lg.
23	735-0196	1	S	Foot Pad
24	683-0049	1	S	Brake Lockout Brkt. Ass'y.
26	732-0728	1		Foot Pedal Return Spring
27	738-0296	1	S	Shld. Bolt .437" Dia. x .268"
28	736-0406	1	S	FI-Wash. 7/16" I.D. x 1-3/8" O.D.
29	747-0608A	1	S	Lock-up Rod Code: N Notates a new part (not previously existing)
30	17755A	1		Bracket
31	736-0119	1	S/F	L-Wash. 5/16" I.D.
32	712-0267	1	S/F	Hex Nut 5/16-18 Thd.
33	720-0166	1	/P	Ball Knob
34	732-0727	1	S	Neutral Return Spring
35	712-0273	1	S	Hex Nut 5/16-24 Thd.
36	736-3078	1	/P	FI-Wash. .344" I.D. x 1" O.D.
37	783-0092	1		Scissor-Flat
38	736-0362	1	/P	FI-Wash. .33" I.D. x 1.25" O.D.
39	750-0808	1	/P	Spacer
40	736-0219	1	S	Bell-Wash. .4" I.D. x 1.13" O.D.
41	761-0196	1	S	Friction Washer
42	750-0918	1		Centering Gauge Spacer
43	783-0095	1		Neutral Return Mtg. Brkt.
44	736-0270	1	/P	Bell-Wash. .265" I.D. x .75" O.D.
45	732-0718	1		Comp. Spring 1.19" Lg.
46	736-3008	1	S	FI-Wash. .312" I.D. x .75" O.D.
47	712-0123	1	/P	Hex Nut 5/16-24 Thd.
48	710-0299	1		Hex Bolt 1/4-28 x 1" Lg. (Gr. 5)
49	710-1012	1	/P	Rib Neck Bolt 5/16-24 x .84" Lg.
50	783-0093	1		Scissor-Offset
51	747-0887	1		Neutral Return Rod
52	738-0879	1	S	Friction Disc Stud
53	748-0368	1		Shld. Spacer
54	783-0096	1		Neutral Return Lever
55	736-3092	1	/P	FI-Wash. .265" I.D. x 1" O.D.
56	736-0329	1	S/F	L-Wash. 1/4" I.D.

13AT696H190 LT-165 (1997)  
Lower Frame, Clutch And Controls

Page 8 of 22

Ref #	Part Number	Qty	S/P/F	Description
57	712-0287	1	S/F	Hex Nut 1/4-20 Thd.
58	714-0104	1	S	Hairpin Clip
59	736-0262	1	/P	Fl-Wash. .375" I.D. x .87" O.D.
60	736-0413	1	/P	Spring Wash. .39" I.D.
61	712-0116	1	S	Hex L-Nut 3/8-24 Thd.
62	712-0711	1	/P	Hex Jam Nut 3/8-24 Thd.
63	783-0097	1		Neutral Return Brkt.
64	711-0832	1	S	Ferrule 3/8-24 Thd.
65	747-0365	1	S	Control Rod
66	723-0351	1	S	Ball Joint 3/8-24 Thd.
67	748-0234	1	/P	Shld. Spacer .5" Dia. x .27" Lg.
68	736-0159	1	S	Fl-Wash. .349" I.D. x .879" O.D.
69	710-3007	1	/P	Hex Wash. Hd. Tap Scr. #12 x 3/8" Lg.
70	731-1449	1	S	Fan
71	712-0333	1	S	Hex Nut 1/2-20 Thd.
72	736-0921	1	S/F	L-Wash. 1/2" I.D.
73	712-0241	1	/P	Hex Nut 3/8-24 Thd.
74	736-0169	1	S	L-Wash. 3/8" I.D.
75	756-0975	1		Transmission Pulley
76	732-0729	1	/P	Wire Ring
77	754-0441	1	S	"V"-Belt
78	756-0981	1	S	Fl-Idler Pulley 2.75" O.D.
79	720-0238	1		Rod End Grip
80	747-0894	1		Bypass Control Lever
81	783-0085	1	S	Transaxle Support Brkt.- L.H.
82	710-0528	1	/P	Hex Bolt 5/16-18 x 1.25" Lg.
83	732-0384	1	S	Ext. Spring 6.12
84	683-0048	1		Idler Brkt. Ass'y.
85	710-0116	1	S/F	Hex Bolt 5/16-18 x 2.5" Lg.
86	710-0118	1	S/F	Hex Bolt 5/16-18 x .75" Lg.
87	748-0234	1	/P	Shld. Spacer .5" Dia. x .27" Lg.
88	783-0086A	1	S	Transaxle Support Brkt.- R.H.
89	747-0886	1		Brake Rod 24.94" Lg.
90	732-0716	1	S	Ext. Spring
91	747-0893	1		Bypass Actuator Rod
92	736-0142	1	S	Fl-Wash. .281" I.D. x .5" O.D.
93	783-0098	1		Bypass Adjustment Brkt.
94	736-0222	1	S	External L-Wash. 1/4" I.D.
95	731-1086A	1	/P	Sleeve .758" I.D. x 1" O.D.
96	710-0604	1	S	Hex Wash. TT-Tap Scr. 5/16-18 x .62" Lg.
97	17994	1	S	Retainer Brkt.-Transaxle
98	710-1266	1	/P	Hex Bolt 5/16-18 x 3.5" Lg.
99	732-0250	1	S	Tension Spring
100	710-0888	1	/P	Hex Bolt 5/16-24 x 1" Lg. (Special)
101	710-0224	1	S	Hex Wash. Hd. AB-Tap Scr. #10 x .5" Lg.
107	647-0008A	1	/P	Speed Control Lever Ass'y.
108	17668	1	S	Axle Support Brkt.- R.H.
	17669	1	S	Axle Support Brkt.- L.H. (Not shown)
109	732-0433	1		Ext. Spring 2.75" Lg.
110	736-0141	1	S	Spr.-Wash. .445" I.D. x .75" O.D.
111	17840	1	S	Transaxle Mtg. Brkt.
112	725-1657A	1	S	Safety Switch (Clutch)
115	710-0650	1	/P	Hex Wash. TT-Tap Scr. 5/16-18 x .75" Lg.



13AT696H190 LT-165 (1997)  
Lower Frame, Clutch And Controls

Page 9 of 22

Ref #	Part Number	Qty	S/P/F	Description
116	683-0123	1		Clutch/Brake Pedal Ass'y. Code: N Notates a new part (not previously existing)
117	750-0802	1		Spacer .63" I.D.
118	17860	1	S	Pedal Bracket
119	736-0264	1	S	FI-Wash. .344" I.D. x .62" O.D.
120	714-0111	1	S	Cotter Pin 3/32" Dia.
121	714-0470	1	S	Cotter Pin 1/8" Dia.
122	736-0256	1	S	FI-Wash. .64" I.D. x .94" O.D.
123	710-0227	1	/P	Hex Wash. Hd. AB-Tap Scr. #8 x .5" Lg.
124	726-0320	1	S	Insulator Nut Plate
125		1		UNKNOWN
126	725-1399	1		Extension Wire
127	710-0344	1	/P	Hex Bolt 3/8-16 x 1.5" Lg.
128	756-0116	1	S	Idler Pulley
130	712-0798	1	/P/F	Hex Nut 3/8-16 Thd.
131	720-0218	1	/P	Shift Knob
133	783-0099	1		Idler Brkt.
134	731-1480	1	/P	Plastic Vent
135	726-0324	1	S	Clamp
136	721-0330	1		"O"-Ring
137	731-1485	1		Hose Fitting
138	751-0588-18	1		Fuel Line 18" Lg.
139	710-0627	1	/P	Hex Bolt 5/16-24 x .75" Lg.
140	736-0242	1	/P	Bell-Wash. .345" I.D. x .88" O.D.
141	734-0255	1	S	Air Valve
142	634-0070	1	/P	Rim Only
143	734-1675	1		Wheel Ass'y. Comp.
	734-1596	1		Tire Only
144	734-1784A	1	S	Hub Cap
145	727-0425A	1	S	Spring Clip
146	731-1481	1		Vent Cap
147	750-0258	1	/P	Spacer .315" I.D. x .75" O.D.
148	710-3195	1		Hex Bolt 5/16-18 x 4.5" Lg.
149	732-0750A	1	S	Spring Switch Code: N Notates a new part (not previously existing)
150	711-1044	1	S	Belt Guard Pin

13AT696H190 LT-165 (1997)  
Muffler And Exhaust

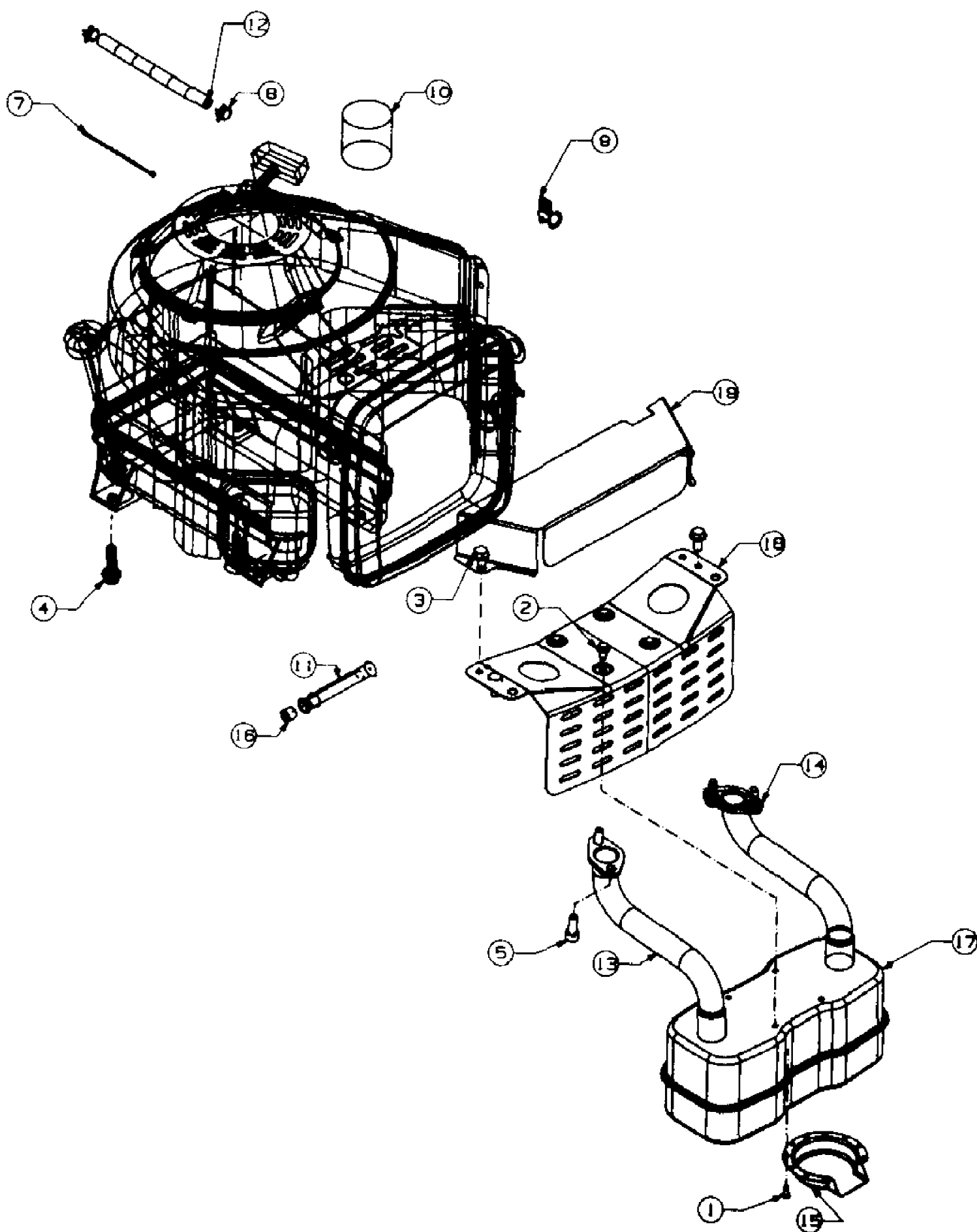

13AT696H190 LT-165 (1997)  
Muffler And Exhaust

Page 11 of 22

Ref #	Part Number	Qty	S/P/F	Description
1	710-0148	1	/P	Hex Tap Scr. #8-32 x .38" Lg.
2	710-0599	1	/P	Hex Wash. TT-Tap Scr. 1/4-20 x .5" Lg.
3	710-0604	1	S	Hex Wash. TT-Tap Scr. 5/16-18 x .62" Lg.
4	710-1315	1	/P	Hex Wash. TT-Tap Scr. 3/8-16 x 1.25" Lg.
5	710-3292	1	/P	Socket Hd. Scr. M8 x 1.25" Lg.
7	726-0197	1		Cable Tie
8	726-0205	1	/P	Hose Clamp
9	726-0272	1	/P	Clamp
10		1		Oil Filter
11	737-0286	1		Pipe Nipple 3/8 x 3.8" Lg.
12	751-0535-26	1	S	Fuel Line
13	751-0558	1		Exhaust Tube - R.H.
14	751-0559A	1	/P	Exhaust Tube - L.H.
15	751-0564	1	S	Deflector
16	751-0572	1		Hex Pipe Plug
17	751-0616	1	S	Muffler
18	783-0320A	1	S	Muffler Bracket
19	783-0356	1		Heat Shield

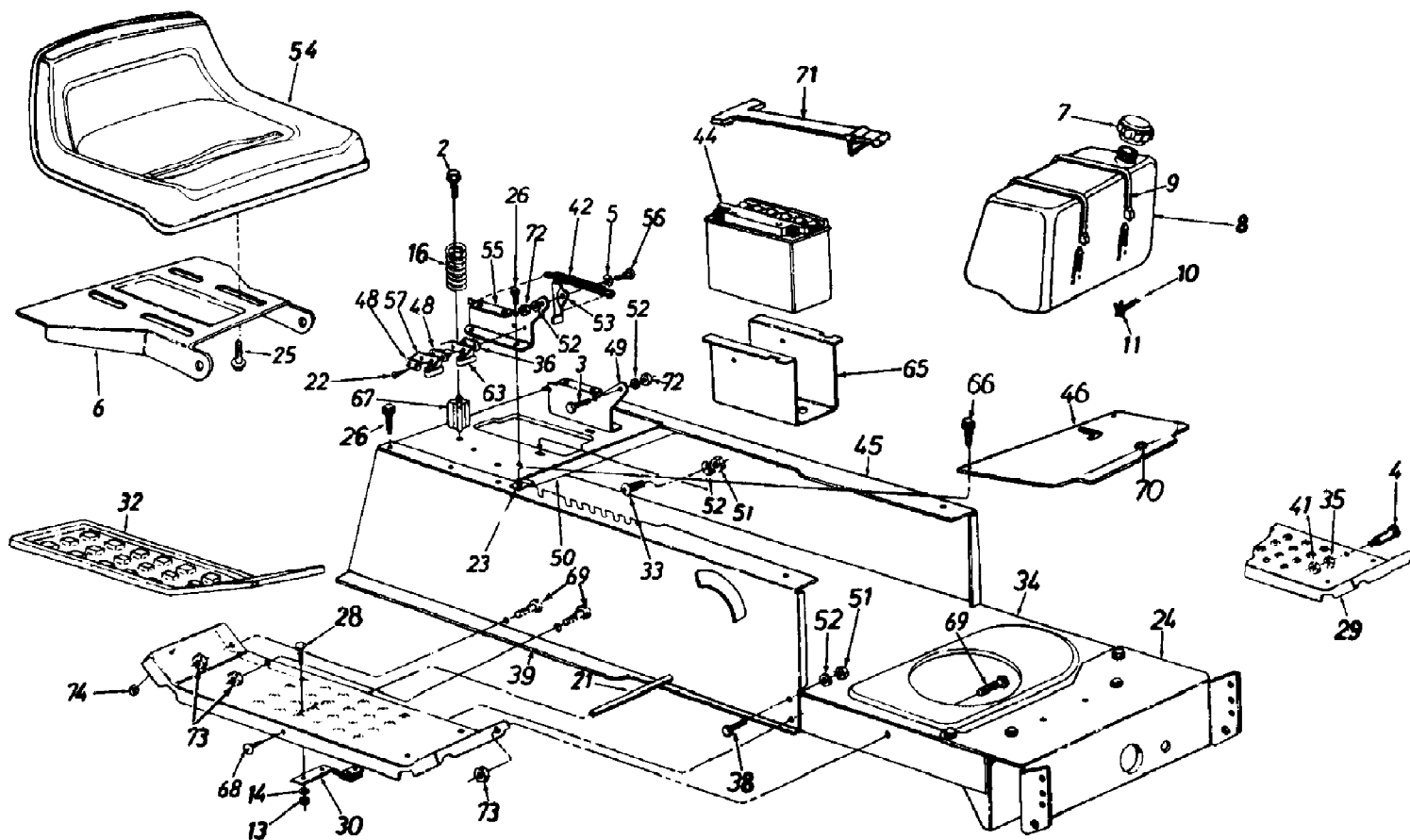

13AT696H190 LT-165 (1997)  
Seat, Lower Frame And Fuel Tank

Page 13 of 22

Ref #	Part Number	Qty	S/P/F	Description
2	710-1208	1	/P	Hex Wash. Hd. Tap Scr. 5/16-18 x 3.25" Lg.
3	738-0155	1	S	Shld. Bolt .437" Dia. x .162"
4	738-0145	1	S	Shld. Bolt .50" Dia. x .84"
5	736-0141	1	S	Spr-Wash. .445" I.D. x .75
6	783-0039A	1	/P	Seat Pivot Bracket
7	751-0603	1	S	Fuel Cap
8	751-0574A	1		Fuel Tank
	749-0934	1		Fuel Tank Support Rod (Not shown)
9	726-0209	1	/P	Tie Strap
10	751-0535-15	1	S	Fuel Line
11	726-0205	1	/P	Hose Clamp
13	712-3006	1	/P	Hex Nut 1/4-20 Thd. (Gr. 5)
14	736-0329	1	S	L-Wash. 1/4" I.D.
16	732-0735	1	/P	Compression Spring
21	738-0526	1		Running Board Rod
22	710-0227	1	/P	Hex AB-Tap Scr. #8 x .50"
23	726-0139	1	/P	Speed Nut #102
24	783-0041A	1	S	Front Pivot Brkt.
25	710-0870	1	/P	Hex Tap Scr. 3/8-16 x .62"
26	710-0726	1	/P	Hex Wash. Hd. AB-Tap Scr. 5/16 x .75" Lg.
28	710-0134	1	/P/F	Carriage Bolt 1/4-20 x .62"
29	17770B	1	S	Running Board (R.H. & L.H.)
30	761-0168A	1	S	Blade Brake Ass'y.
32	731-0909	1	S	Rubber Foot Pad - L.H.
	731-0910	1	S	Rubber Foot Pad - R.H.
33	710-0323	1	/P/F	Truss Mach. Scr. 5/16-18 x .75" Lg.
34	783-0310B	1	S	Lower Frame
35	736-0169	1	S/F	L-Wash. 3/8" I.D.
36	726-0278	1		Insulator Boss Plate
38	710-0118	1	S/F	Hex Bolt 5/16-18 x .75" Lg.
39	783-0042A	1	S	Upper Frame - R.H.
41	712-0798	1	/P/F	Hex Nut 3/8-16 Thd.
42	732-0581B	1	S	Extension Spring 5.31" Lg.
44	725-1707B	1	S	12-V Battery
45	783-0043	1	/P	Upper Frame - L.H.
46	783-0133A	1	S	Shift Cover
48	726-0279	1		Insulator Plate
49	17951	1	S	Seat Pivot Brkt. Support - L.H.
50	783-0355	1	S	Hitch Plate
51	712-0267	1	S/F	Hex Nut 5/16-18 Thd.
52	736-0119	1	S/F	L-Wash. 5/16" I.D.
53	17239A	1	S	Seat Lift Brkt.
54	757-0370A	1	S	Seat
55	17950	1	S	Seat Pivot Brkt. Support - R.H.
56	738-0296	1	S	Shld. Bolt .437" Dia. x .268"
57	725-1303	1	S	Spring Switch
63	725-1439	1		Safety Switch (Seat)
65	783-0345	1	S	Battery Tray
66	710-0351	1	/P	Truss Mach. B-Tap Scr. #10 x .5" Lg.
67	748-0347	1	S	Spring Spacer
68	710-0323	1	/P	Pan Hd. Scr. 5/16-18 x .75" Lg.
69	710-0118	1	S/F	Hex Bolt 5/16-18 x .75" Lg.
70	731-0405	1		Snap Bushing

13AT696H190 LT-165 (1997)  
Seat, Lower Frame And Fuel Tank

Ref #	Part Number	Qty	S/P/F	Description
71	723-3064	1		Battery Retainer Strap
72	712-3010	1	S	Hex Nut 5/16-18 Thd. (Gr. 5)
73	712-0265	1	/P	Hex Sems Nut 5/16-18 Thd.
74	712-0271	1	/P	Hex Sems Nut 1/4-20 Thd.

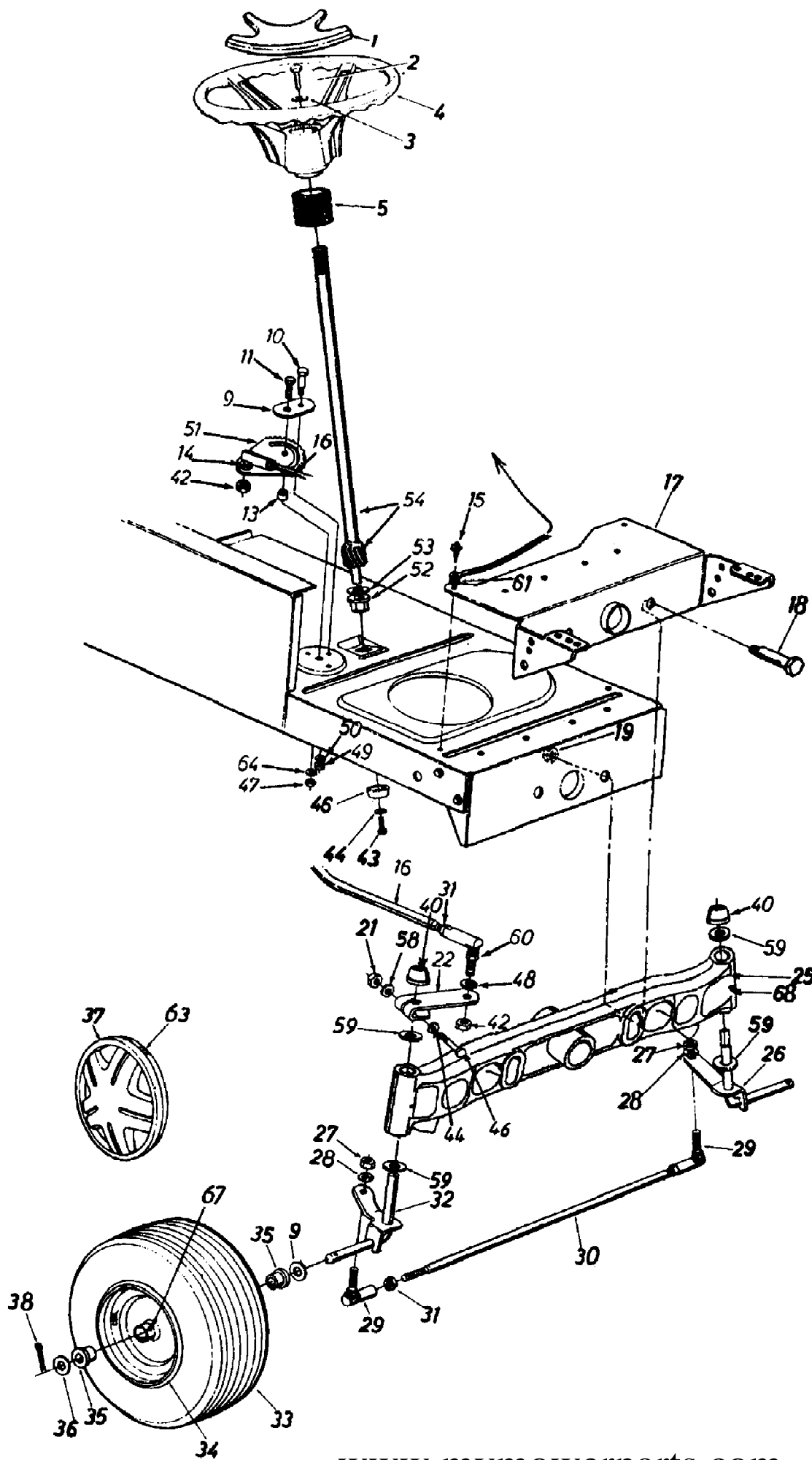

13AT696H190 LT-165 (1997)  
Steering And Front Wheel Ass'y

Page 16 of 22

Ref #	Part Number	Qty	S/P/F	Description
1	731-1509A	1	/P	Steering Wheel Cap
2	710-0643	1	/P	Hex Bolt 5/16-18 x 1" Lg.
3	736-0242	1	/P	Belleville Wash. .345" I.D.
4	731-1686	1	S	Steering Wheel
5	731-0954	1	S	Steering Bellow - 9"
9	17198A	1	S	Retainer Plate
10	738-0141	1	S	Shoulder Bolt .437" Dia. x .35" Lg.- 5/16-18 Thd.
11	710-0152	1	S	Hex Bolt 3/8-24 x 1.0" Lg. (Grade 5)
13	750-0535	1	S	Spacer.380" I.D. x .625" O.D. x .227
14	736-0217	1	S	L-Wash. 3/8" I.D. (H.D.)
15	710-0726	1	/P	Hex Wash. Hd. Self-Tap Scr.
16	711-1107	1	S	Steering Drag Link
17	783-0041A	1	S	Pivot Bar Brkt.
18	738-0527	1	S	Shoulder Bolt .498" Dia. x 2.04" Lg.- 3/8-16 Thd.
19	712-0431	1	S/F	Flanged Hex Nut 3/8-16 Thd.
21	712-0411	1	S	Hex L-Nut 5/16-24 Thd.
22	683-0055	1	S	Steering Arm Front Axle
?23	710-0772	1	/P	Hex Bolt 5/16-24 x 2.00" Lg. (Grade 5)
25	719-0342	1	S	Pivot Bar Ass'y.
26	683-0125	1	S	Front Axle Ass'y.- L.H.
27	712-0241	1	/P/F	Hex Nut 3/8-24 Thd.
28	736-0169	1	S/F	L-Wash. 3/8" I.D.
29	723-3018	1	S	Ball Joint 3/8-24 Thd.
30	747-0753	1		Tie Rod
31	712-0711	1	/P/F	Hex Jam Nut 3/8-24 Thd.
32	683-0124	1	S	Front Axle Ass'y.- R.H.
33	634-0059	1		Wheel Ass'y. Comp.
	734-0864	1	/P	Tire Only
	734-0255	1	S	Air Valve
34	634-0051	1	S	Front Wheel Rim Only
35	741-0569	1	S	Bearing
36	736-0285	1	/P	FI-Wash. .635" I.D. x 1.59" O.D.
37	731-1783A	1		Hub Cap
38	714-0470	1	S/F	Cotter Pin 1/8" Dia. x 1.25"
?39	736-0531	1	S	FI-Wash. .640" I.D. x 1.24" O.D.
40	726-0214	1	/P	Push Cap 5/8" Dia. Rod
42	712-0262	1	/P	Hex Jam Nut 3/8-24 Thd.
43	710-1309	1	/P	Torx Bolt 5/16-18 x .63" Lg.
44	736-0119	1	S/F	L-Wash. 5/16" I.D.
?45	736-0343	1	/P	FI-Wash. .33" I.D. x 1.25" O.D.
46	748-0389	1	S	Cap
47	712-0214	1	S	Hex Cent. L-Nut 3/8-24 Thd.
48		1		UNKNOWN
49	712-0158	1	S	Hex Cent. L-Nut 5/16-18 Thd.
50	736-0119	1	S/F	L-Wash. 5/16" I.D.
51	717-0622A	1	S	Steering Gear Segment
52	741-0656	1	S	Hex, Flg. Brg. 5/8" I.D.
53	736-0187	1	/P	FI-Wash. (Hardened)
54	738-0919	1	S	Steering Shaft
58	736-0271	1	S	Wave Wash. .32" I.D. x .62" O.D.



13AT696H190 LT-165 (1997)  
Steering And Front Wheel Ass'y

Page 17 of 22

Ref #	Part Number	Qty	S/P/F	Description
59	736-0187	1	/P	FI-Wash. (Hardened)
60	723-0448	1	S	Drag Link Ball Joint 3/8-24 Thd.
61	736-0607	1	/P	Ext. L-Wash. 5/16" I.D.
63	727-0425A	1	S	Spring Clip
64	736-0356	1	S	Bell-Wash. .39" I.D. x 1.38" O.D.
67	737-0280	1	S	Grease Fitting
68	737-3000	1	S	Grease Fitting

TORQUE TO 80-100 IN-LBS.

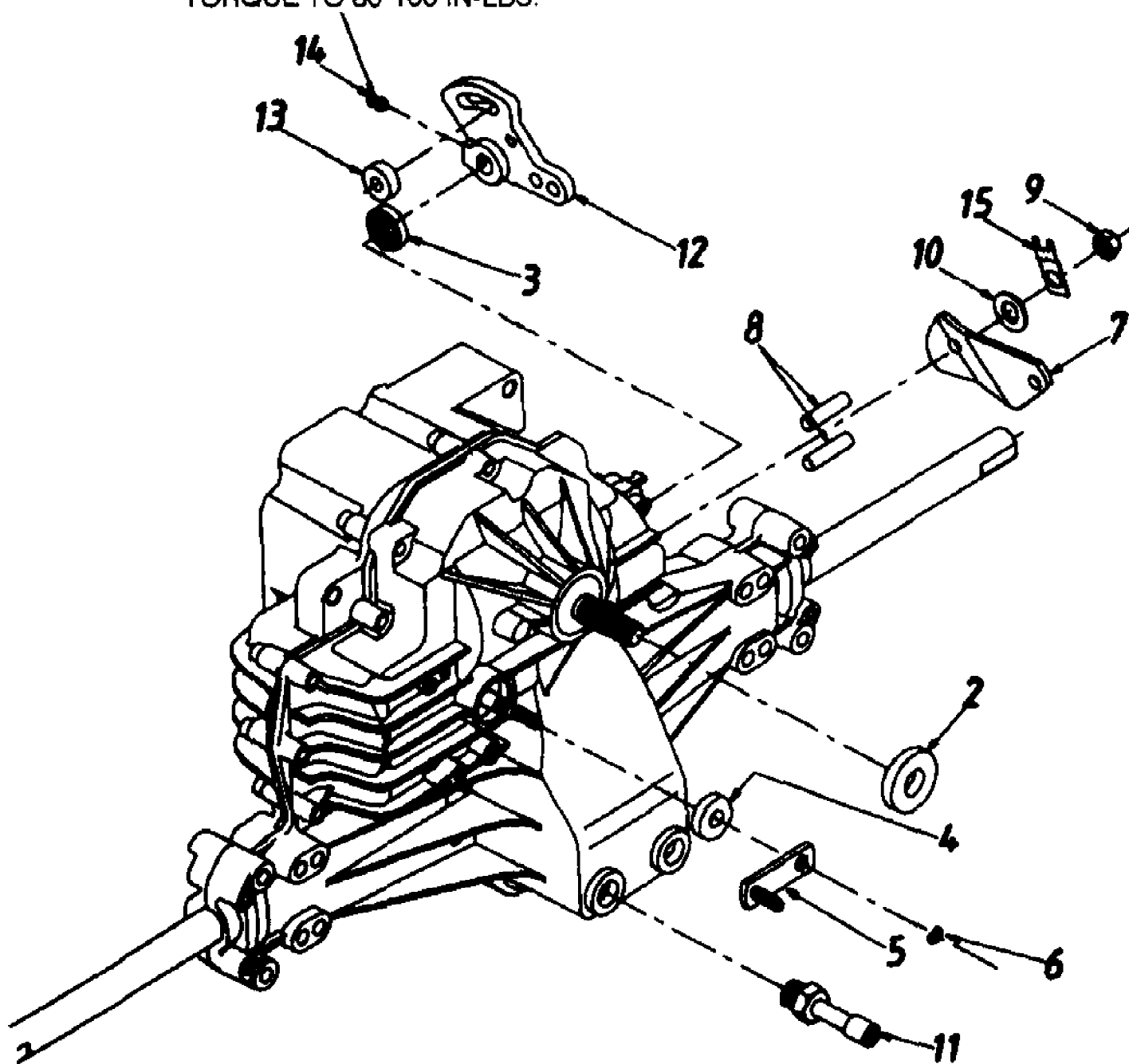

13AT696H190 LT-165 (1997)  
Transmission

Page 19 of 22

Ref #	Part Number	Qty	S/P/F	Description
?1	718-0255A	1	S	Transmission Comp.
2	HG-9008000-0128	1	/P	Seal - Lip
3	HG-9008000-0126	1	/P	Seal - Lip
4	HG-45074	1	/P	Seal - Lip 10 x 25 x 7
5	HG-50126	1		Arm - Bypass
6	HG-44870	1		Ring - Retaining
7	HG-44094	1	/P	Arm - Actuating
8	HG-44891	2	/P	Pin - Actuating
9	HG-50108	1	S	Nut - Hex Lock 5/16-24 UNJC
10	HG-44130	1	S	Washer 7/16" x 7/8" x .060"
11	HG-50042	1		Breather Ass'y.
12	HG-45007	1	/P	Arm - Control
13	HG-50034	1		Puck - Dampener
14	HG-50018	1		Set Screw
15	HG-50129	1		Strap, Locking

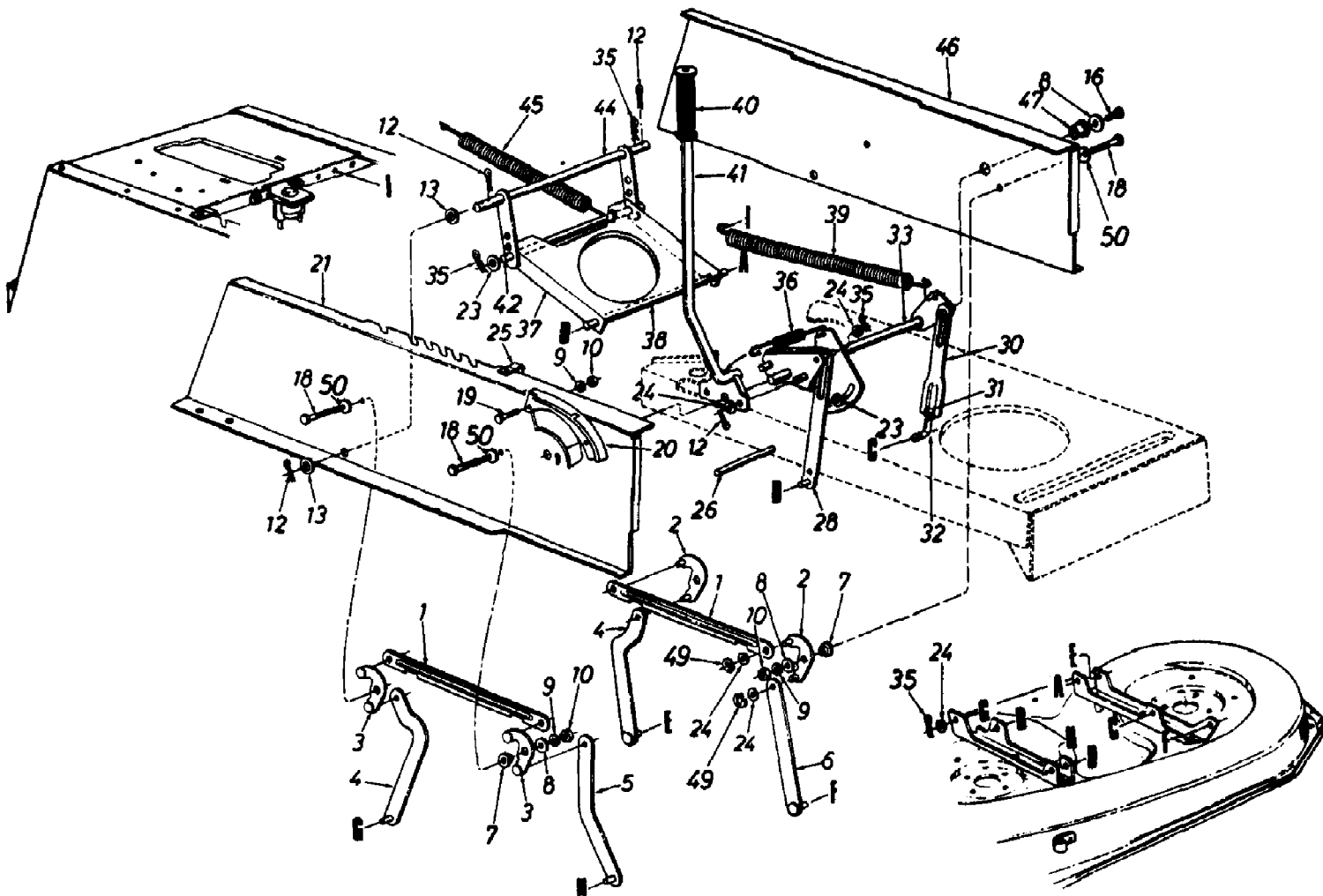

13AT696H190 LT-165 (1997)  
Upper Frame And Mower Deck Linkage

Page 21 of 22

Ref #	Part Number	Qty	S/P/F	Description
1	783-0103	1	S	Connecting Rod
2	683-0029A	1	S	Pivot Link Ass'y.- L.H.
3	683-0028A	1		Pivot Link Ass'y.- R.H.
4	17710	1	S	Deck Hanger Link Ass'y.
5	14800A	1	S	Deck Hanger Link Ass'y.
6	14804A	1		Deck Hanger Link Ass'y.
7	748-0331	1	S	Shld. Spacer .318" I.D.
8	736-0264	1	S	FI-Wash. .344" I.D. x .62" O.D.
9	736-0119	1	S/F	L-Wash. 5/16" I.D.
10	712-0265	1	/P/F	Hex Nut 5/16-18 Thd.
12	714-0470	1	S	Cotter Pin 1/8" Dia.
13	736-0256	1	S	FI-Wash. .635" I.D. x 1.0" O.D.
16	710-0604	1	S	Hex Wash. TT-Tap Scr. 5/16-18 x .75" Lg.
18	710-1238	1	/P	Hex Wash. Hd. Scr. 5/16-18 x .875" Lg.
19	710-0118	1	S	Hex Bolt 5/16-18 x .75" Lg.
20	783-0185	1		Index Brkt.
21	783-0042A	1	S	Upper Frame - R.H.
23	736-0267	1	S	FI-Wash. .385" I.D. x .87" O.D.
24	736-0160	1	S	FI-Wash. .531" I.D. x .93" O.D.
25	726-0272	1	/P	Clamp
26	738-0526	1		Running Board Rod
28	14802A	1	S	Link Deck Lift Ass'y.
30	17712	1	S	Adj. Deck Lift Link
31	712-3066	1	S	Hex Nut 1/2-20 Thd. (Gr. 5)
32	711-0841	1	S	Lift Link Adjuster
33	683-0059	1	S	Lift Shaft Ass'y.
35	714-0145	1	S	Inter. Cotter Pin 3/8" Dia.
36	732-0637	1	S	Extension Spring
37	17636B	1	S	Stabilizer Bracket
38	738-0670	1	S	Shaft 1/2" Dia. x 10.28" Lg.
39	732-0638	1		Extension Spring
40	720-0233	1	S	Grip (Lift Handle)
41	17675A	1	S	Deck Lift Handle Ass'y.
42	738-0669	1		Shaft 3/8" Dia. x 9.34" Lg.
44	17624	1	S	Stabilizer Shaft Ass'y.
45	732-0556	1	S	Extension Spring 7.58" Lg.
46	783-0043	1	/P	Upper Frame - L.H.
47	741-0487A	1	S	Flange Brg. .632" I.D.
49	716-0104	1	S	"E"-Ring
50	736-0425	1	S	Bell-Wash. .325" I.D.

